



# IntelliBrite™

## Underwater Spa LED Color-Changing Light



## Installation and User's Guide

IMPORTANT SAFETY INSTRUCTIONS  
READ AND FOLLOW ALL INSTRUCTIONS  
SAVE THESE INSTRUCTIONS



**© 2007 Pentair Water Pool and Spa, Inc. All rights reserved**

1620 Hawkins Ave., Sanford, NC 27330 • (919) 566-8000  
10951 West Los Angeles Ave., Moorpark, CA 93021 • (805) 553-5000

IntelliBrite is a trademark of Pentair Water Pool and Spa, Inc. The Pentair Water Pool and Spa logo is a registered trademark of Pentair Water Pool and Spa, Inc. Other trademarks and trade names may be used in this document to refer to either the entities claiming the marks and names or their products. Pentair Water Pool and Spa, Inc. disclaims proprietary interest in marks and names of others.

## Contents

<b>IMPORTANT SAFETY PRECAUTIONS .....</b>	<b>ii</b>
IntelliBrite™ underwater Spa LED Color-Changing Light .....	1
Operating the IntelliBrite LED light using a wall switch .....	1
Selecting a light show mode or fixed color .....	1
Saving a color mode or fixed color .....	2
Hold and Recall feature .....	2
Powering on the light .....	2
Troubleshooting .....	2
IntelliBrite Spa light fixture Installation .....	3
Installing the IntelliBrite Spa light fixture (New Pool Construction) .....	3
Installing the IntelliBrite Spa light after electrical requirements are met .....	3
Replacing the IntelliBrite Spa light assembly in an existing spa .....	4
Before replacing the IntelliBrite Spa light fixture .....	4
Replacing the IntelliBrite Spa light fixture after electrical requirements are met .....	5
Replacing the IntelliBrite Spa light Assembly using a Replacement Kit .....	6
IntelliBrite Spa Light Replacement Kit Part Numbers .....	10

# IMPORTANT SAFETY PRECAUTIONS



## Important Notice:

**Attention Installer:** This manual contains important information about the installation, operation and safe use of this product. This information should be given to the owner and/or operator of this equipment.

**⚠ WARNING** - Before installing the IntelliBrite underwater Spa LED light, read and follow all warning notices and instructions which are included. Failure to follow safety warnings and instructions can result in severe injury, death, or property damage. Call (800) 831-7133 for additional free copies of these instructions.



## **DANGER! Risk of Electrical Shock or Electrocution!**



This underwater light must be installed by a licensed or certified electrician or a qualified pool serviceman in accordance with the National Electrical Code and all applicable local codes and ordinances. Improper installation will create an electrical hazard which could result in death--- or serious injury to pool users, installers or others due to electrical shock, and may also cause damage to property. Always disconnect the power to the pool light at the circuit breaker before servicing the light. Failure to do so could result in death or serious injury to serviceman, pool users or others due to electrical shock. **READ AND FOLLOW ALL INSTRUCTIONS IN THIS MANUAL.**



### **WARNING Important Safety Information for Pentair Niche and Light Installation**

- All Niche and Light installations must conform with all codes. If local codes mandate a cord seal, use Pentair plastic niches (P/N 79206600 and P/N 79206700).
- Under no circumstances replace lights by splicing wire under water or behind niche.



### **WARNING RISK OF ELECTRIC SHOCK AND INJURY. USE ONLY THE INSTALLATION METHOD SPECIFIED BELOW.**

Location of Luminaire Use	Pentair Fountain Fixture* (P/N 560001 and P/N 560000)	Required Installation Method
Swimming Pool and Spa	Wet-Niche Swimming Pool (or Spa) Luminair (Light)	Fixture Housing (Forming Shell) ONLY. <b>DO NOT USE</b> Fountain Fixture Stand.
Fountain	Wet-Niche Submersible Luminaire (Light) swimming Pool (or Spa) Luminair (Light)	Fixture Housing (Forming Shell) or Fountain Fixture Stand.

(\* **Note:** Wet-niche luminaires complying with requirements for both uses may bare both the Listed Wet-Niche Submersible Luminaires UL Mark. A luminaire not bearing the corresponding UL Listing Mark is not considered by UL to have been produces under UL's Listing and Follow-Up Service for the associated usage location.

**CAUTION:** The Pentair IntelliBrite LED light fixture must only be used with Pentair fixture housings (niches). If the IntelliBrite LED light fixture is installed into other niches, the installation will not carry U.L. approval and will void all warranties.

## Technical Support

**Sanford, North Carolina** (8 A.M. to 5 P.M. ET)

**Moorpark, California** (8 A.M. to 5 P.M. PT)

**Phone:** (800) 831-7133

**Fax:** (800) 284-4151

**Web sites:** visit [www.pentairpool.com](http://www.pentairpool.com) and [www.staritepool.com](http://www.staritepool.com)

# IntelliBrite™ Underwater Spa LED Color-Changing Light

The IntelliBrite underwater spa LED (light-emitting diode) light system gives you brilliant vivid multi-colors with spectacular effects for your pool. The energy efficient colored LED array can cycle through colors at varying speeds and in different sequences of color. The unique IntelliBrite lens geometry provides a wider beam for greater underwater light reflection providing increased light intensity. Choose one of the seven pre-programmed color light shows or select one of the five fixed colors to create virtually endless range of dramatic underwater lighting effects.

IntelliBrite LED lights are fully compatible with Pentair IntelliTouch and EasyTouch automation system. For more information about using IntelliBrite lights with IntelliTouch systems, refer to the IntelliTouch User's Guide (P/N 520102) and the EasyTouch User's Guide (P/N 520584).

## Operating IntelliBrite LED lights using a wall switch

IntelliBrite LED lights can be controlled using a standard wall-mount light switch. Multiple IntelliBrite LED lights can be connected via a junction box to a single switch so that all lights can be switched on and off together. IntelliBrite LED lights are controlled by cycling AC power from a standard wall switch. By turning the switch on and off a specific number of times, the light activates one of the seven light show modes, fixed colors, and enables the "Hold" and "Recall" feature.

### Selecting a light show mode or fixed color

Switch power on to the light. A white light will momentarily illuminate, followed by the previously selected color. To select a color show mode (1-7) or fixed color (8-12), turn the wall switch off/on a specific number of times. Each number (1-12) shown below corresponds to the number of times to power-cycle the switch to activate a color light show or fixed color. For details about saving color effects while in "show" modes, see "Hold" and "Recall" feature on page 2.

1. **SAm® Mode:** Cycles through white, magenta, blue and green colors (emulates the Pentair SAm light).
2. **Party Mode:** Rapid color changing building energy and excitement.
3. **Romance Mode:** Slow color transitions creating a mesmerizing and calming effect.
4. **Caribbean Mode:** Transitions between a variety of blues and greens.
5. **American Mode:** Patriotic red, white and blue transition.
6. **California Sunset Mode:** Dramatic transitions of orange, red and magenta tones.
7. **Royal Mode:** Richer, deeper color tones.
8. **Blue:** Fixed color.
9. **Green:** Fixed color.
10. **Red:** Fixed color.
11. **White:** Fixed color.
12. **Magenta:** Fixed color.
13. **Hold:** Save the current color effect during a color light show.
14. **Recall:** Activate the last saved color effect.

Example: To select **California Sunset Mode**; turn the switch off and on six successive times.

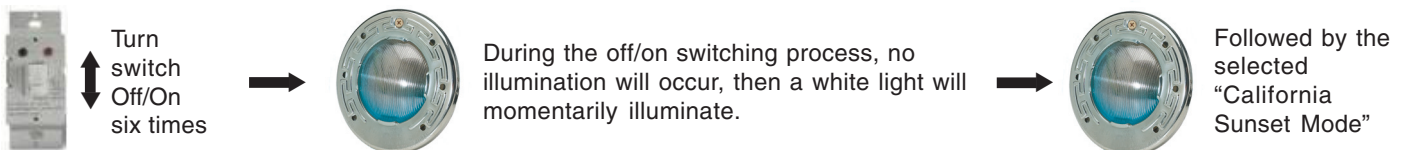

**⚠ WARNING** During the off/on switching process, before the selected color is displayed, no illumination will occur. This operating mode is normal during the switching process. During this period the pool and spa will be dark and precautions should be taken to avoid unforeseen accidents. Failure to observe this warning may result in serious injury or death to pool and spa users.

## Operating IntelliBrite LED Lights using a wall switch (Continued)

### Saving a color mode or fixed color

When power is switched **off** to the IntelliBrite lights, the last color show mode or fixed color will be saved. The next time the light is powered on, the previously saved color show mode or fixed color will be displayed. For example, while in “Party Mode” switch the light off. Wait more than 10 seconds, switch the light back on to resume “Party Mode.”

### Hold and Recall feature

**Hold:** Use the **Hold** feature (power-cycle 13 times) to capture and save a color effect while displaying one of the light show modes. It's easier to capture custom color effects from one of the slower light show modes, such as “Romance Mode” (#3).

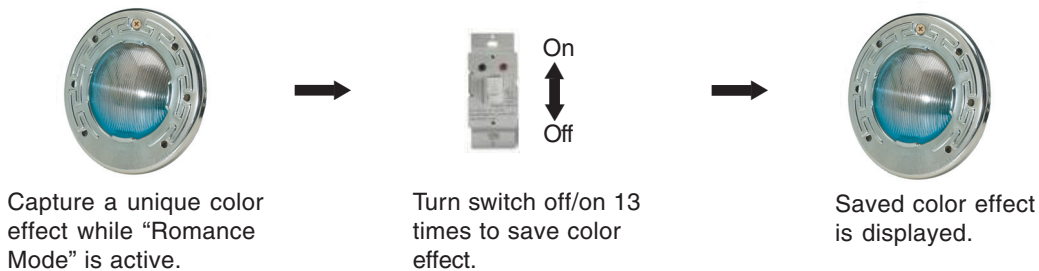

**Recall:** Use the **Recall** feature to activate the last saved color effect (using the **Hold** feature) while in color show mode or fixed colors. To recall the color effect, power-cycle 14 times, and after five seconds the last saved color effect will be displayed.



### Powering on the light

When the IntelliBrite LED light is powered on, a momentarily white light will illuminate, followed by the previously selected color.

**Note:** If power to the light is off for more than five seconds, the last color show mode or fixed color that was saved will be displayed.

### Troubleshooting

Use the following tips to help to resolve problems that might occur while operating the LED light.

Problem	Cause/Action
The light will not illuminate.	Check the ground fault wiring and reset if necessary.
Light does not function properly.	Check the light wiring connection to the junction box at the pool side and to the AC power switch.  Be sure that there is proper AC power applied to the light.



## INTELLIBRITE LED SPA LIGHT INSTALLATION

The following describes how to install the IntelliBrite spa light fixture. Read through pages 3 through 8 before starting the installation procedure.

### Installing the IntelliBrite LED light fixture (new pool construction)

**BEFORE STARTING:** The following steps (1-6) describe the tasks that must be completed by the electrician before the IntelliBrite light fixture is installed. See Figure 1 diagram.

Be sure that the pool meets the requirements of the current National Electrical Code (N.E.C.) Article 680-22 and all local codes and ordinances. A licensed or certified electrician must install the electrical system to meet or exceed those requirements before the underwater light is installed. Some of the requirements of the National Electrical Code which the pool's electrical system must meet are as follows:

- The lighting circuit has a Ground Fault Circuit Interrupter (GFCI) for line voltage models, and has an appropriately rated circuit breaker.
- The Junction Box (or, for 12 volt models, the low voltage transformer) is located at least 8 inches above the maximum water level of the pool and at least 48 inches from the edge of the pool; see Figure 1.
- The light fixture and all metal items within 5 feet of the pool are properly electrically bonded.
- The wet niche is properly installed so that the top edge of the underwater light's lens is at least 18 inches below the surface of the water in the pool/spa; see Figure 1. (Not more than 20" depth in Canada.)
- The wet niche is properly electrically bonded and grounded via the No. 8 AWG ground connector located at the rear of the niche; see Figure 1.

**Note:** The pool or spa electrical system can be verified with a Pool and Spa Electrical Qualification Test Kit. The test kit is available from Pentair Water Pool and Spa, Inc. The electrical system inspection using this kit must be performed by trained and certified personnel.

- To be certain that the pool's electrical system meets all applicable requirements, the electrician should also consult the local building department.
- Use only Pentair Pool Products wet niches to insure proper bonding and grounding connections.

### Installing the IntelliBrite Spa light Fixture after electrical requirements are met

1. Feed cord through conduit to Junction Box, leaving at least four (4) feet of cord at the light fixture to coil around the light; see Figure 1. The four (4) feet of cord around the light allows the light to be serviced after the spa is filled with water.

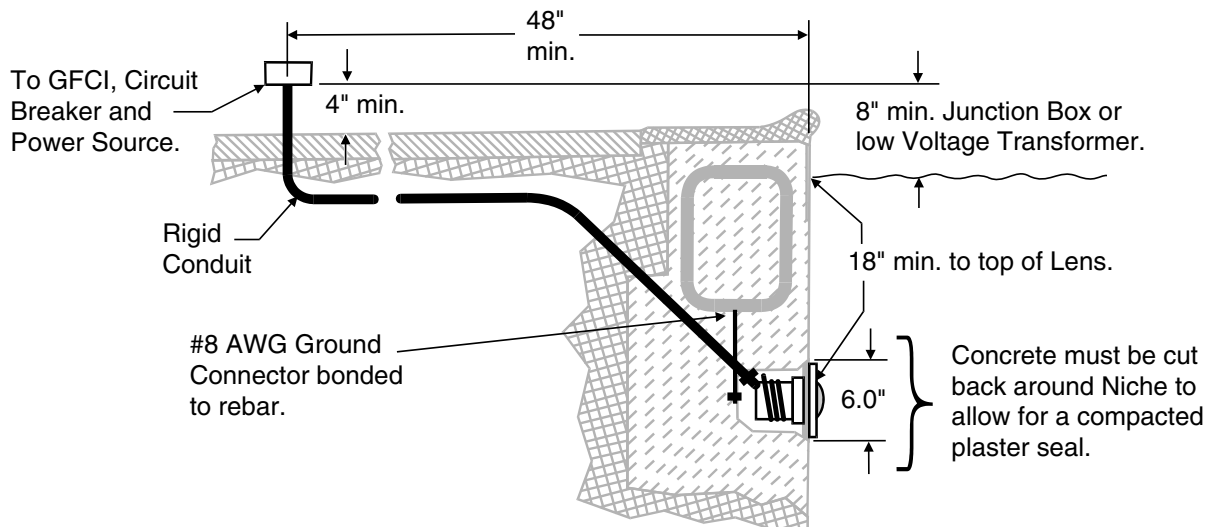



Figure 1

2. Cut the cord at the Junction Box, leaving at least six (6) inches of cord to make connections.
3. Strip 6 inches of the outer cord jacket to expose the three insulated wires (be careful not to damage the insulation on the three inner wires).
4. Connect all three (3) wires to the corresponding circuit wires in the Junction Box and secure the Junction Box cover in place.

 **WARNING** - Never operate this underwater light for more than ten (10) seconds unless it is totally submerged in water. Without total submersion, the light assembly will get extremely hot, which may result in serious burns or in breakage of the lens. This may result in serious injury to pool users, installers, or bystanders, or in damage to property.

5. Install the IntelliBrite light assembly into the niche. Tighten the special bronze pilot screw to secure in place.

 **WARNING** - Use only the special pilot screw provided with this underwater light. This screw mounts and electrically grounds the housing securely to the mounting ring and wet niche. Failure to use the screw provided could create an electrical hazard which could result in death or serious injury to pool users, installers or others due to electrical shock.

6. Fill the spa until the light is completely submerged in the water. Before powering on the light, be sure the light is completely submerged in the water. The light should **never** be powered on out of the water for more than 10 seconds.

**Final check for proper light operation:** Switch on the main switch or circuit breaker, as well as the switch which operates the light itself. The light should illuminate what power is applied. If not recheck the installation steps starting with Step 1 (page 3)

## Replacing the IntelliBrite Spa Light fixture in an existing spa

### **DANGER! Risk of Electrical Shock or Electrocutation!**



The IntelliBrite underwater LED spa light must be installed by a licensed or certified electrician or a qualified pool serviceman in accordance with the National Electrical Code and all applicable local codes and ordinances. Improper installation will create an electrical hazard which could result in death or serious injury to pool users, installers or others due to electrical shock, and may also cause damage to property.

Always disconnect the power to the pool light at the circuit breaker before servicing the light. Failure to do so could result in death or serious injury to serviceman, pool users or others due to electrical shock.

## Before replacing the IntelliBrite Spa Light fixture

Verify that the pool and spa meets the requirements of the current National Electrical Code and all local codes and ordinances. A licensed or certified electrician must install the electrical system to meet or exceed those requirements before the underwater light is installed. Some of the requirements of the National Electrical Code which the pool and spa's electrical system must meet are as follows:

- The lighting circuit has a Ground Fault Circuit Interrupter (GFCI) for line voltage models, and has an appropriately rated circuit breaker.
- The Junction Box (or, for 12 volt models, the low voltage transformer) is located at least 8 inches above ground level and at least 48 inches from the edge of the spa; see Figure 1.
- The light fixture and all metal items within 5 feet of the spa are properly electrically bonded.
- The wet niche is properly installed so that the top edge of the underwater light's lens is at least 18 inches below the surface of the water in the spa; see Figure 1.
- The wet niche is properly electrically bonded and grounded via the No. 8 AWG ground connector located at the rear of the niche; see Figure 1.

**Note:** The pool or spa electrical system can be verified with a Pool and Spa Electrical Qualification Test Kit. The test kit is available from Pentair Water Pool and Spa, Inc. The electrical system inspection using this kit must be performed by trained and certified personnel.

- To be certain that the spa's electrical system meets all applicable requirements, the electrician should also consult the local building department.
- Use only Pentair Pool Products wet niches to insure proper bonding and grounding connections.



## Replacing the IntelliBrite Spa Light fixture after electrical requirements are met

**Note:** The IntelliBrite Spa Light fixture is a sealed light assembly which is replaceable. The lens, gasket and facering can be removed from the sealed light assembly for replacement. See page 9 for replacement kit part numbers.

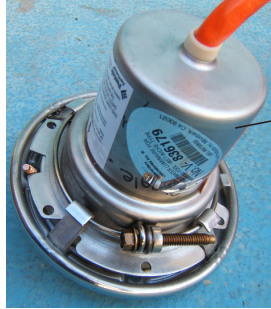

IntelliBrite spa light fixture with lens, gasket and facering attached

**⚠ WARNING** - Failure to bring the pool and spa's electrical system up to code requirements before installing the underwater light will create an electrical hazard which could result in death or serious injury to pool users, installers, or others due to electrical shock, and may also cause damage to property.

1. **Switch off main electrical switch** or circuit breaker, as well as the switch which operates the IntelliBrite underwater light itself.
2. **To remove the spa light fixture from the spa.** Remove the special bronze pilot screw at top of face ring. Remove the IntelliBrite spa light fixture from the niche and place it on the deck (see page 6 for removal instructions).

**⚠ WARNING** - Be sure to keep the special pilot screw from this underwater light. This screw mounts and electrically grounds the housing securely to the mounting ring and wet niche. Failure to use the screw provided could create an electrical hazard which could result in death or serious injury to pool users, installers or others due to electrical shock.

3. Remove Junction Box cover, disconnect the light fixture wires, and pull the cord through the conduit.
4. Feed the new light fixture cord through the conduit from the niche to the Junction Box. **Note:** Depending on the length of the conduit, special tools may be required to pull the cord through the conduit.
5. Leave at least four (4) feet of cord to coil around the light fixture; see Figure 1 on page 2. This four (4) feet of cord coiled around the light allows the light to be serviced after the spa is filled with water.
6. Cut the cord at the Junction Box, leaving at least size (6) inches of cord to make connections.
7. Strip six (6) inches of the outer cord jacket from the cord to expose the three (3) insulated wires – be careful not to damage the insulation on the three inner wires.
8. Connect all three (3) wires to the corresponding circuit wires in the Junction Box (black wire to power, white wire to common, and green wire to ground) and secure the Junction Box cover in place.

**⚠ WARNING** - Never operate this underwater light for more than ten (10) seconds unless it is totally submerged in water. Without total submersion, the light assembly will get extremely hot, which may result in serious burns or in breakage of the lens. This may result in serious injury to pool and spa users, installers, or bystanders, or in damage to property.

9. Replace the IntelliBrite spa light fixture into the niche and tighten the special pilot screw.

**⚠ WARNING** - Use only the special pilot screw provided with this underwater light. This screw mounts and electrically grounds the housing securely to the mounting ring and wet niche. Failure to use the screw provided could create an electrical hazard which could result in death or serious injury to pool users, installers or others due to electrical shock.

10. Fill the pool and/or spa until the IntelliBrite spa light fixture is completely submerged in water before operating the light for more than 10 seconds. Switch on main switch or circuit breaker, as well as the switch which operates the IntelliBrite spa light itself to verify that the light is operating correctly.

## Replacing the IntelliBrite Spa LED Light Assembly using a Replacement Kit (see page 10 for Replacement Kit part numbers)

### **DANGER!**

#### **RISK OF ELECTRICAL SHOCK OR ELECTROCUTION**

Always disconnect power to the spa light at the circuit breaker before servicing the light. Failure to do so could result in death or serious injury to installer, serviceman, spa users, or others due to electrical shock.

1. **Switch off main electrical switch** or circuit breaker, as well as the switch which operates the IntelliBrite underwater light itself.
2. Before starting be sure that you have a new lens gasket (P/N 79101600) and an IntelliBrite LED spa light assembly ready to install.

 **WARNING** - Replace the LED light assembly with the same type and wattage. Failure to replace the LED light assembly with the same type will damage the LED light fixture and may cause an electrical hazard resulting in death or serious injury to pool and spa users, installers, or others due to electrical shock, and may also cause damage to property.

 **WARNING** - Always install a new lens gasket (part number 79101600) whenever disassembling the IntelliBrite LED light fixture. Failure to do so may permit water to leak into the assembly which could cause:

- (a) an electrical hazard resulting in death or serious injury to pool users, installers, or others due to electrical shock, or
- (b) breakage of the lens, which likewise could result in serious injury to pool and spa users, installers, or bystanders, or in damage to property.

3. **REMOVING THE INTELLIBRITE LED LIGHT:** Remove the pilot screw at top of face ring, remove the light assembly from the niche. Place the assembly on the deck. **Note:** It is not necessary to drain down the spa.

Pilot screw

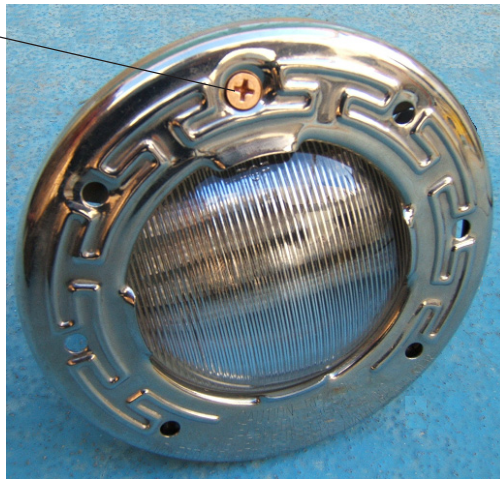

 **WARNING** - Be sure to keep the pilot screw from the IntelliBrite LED underwater light. This screw mounts and electrically grounds the housing securely to the mounting ring and wet niche. Failure to use the screw provided could create an electrical hazard which could result in death or serious injury to pool and spa users, installers or others due to electrical shock.

4. Using a number three (3) Phillips head screwdriver loosen the screw and remove uni-tension wire clamp from the face ring.
5. Remove the face ring and wire clamp from the light housing and set aside for installation later.

Note: Transformer required  
on 12 VDC models

Loosen the Phillips screw to  
remove wire clamp



6. With the light assembly resting on its base, carefully pry off the gasket to release the lens. Discard the gasket. A NEW LENS GASKET MUST BE USED EACH TIME THE SPA LED LIGHT IS REASSEMBLED
7. Disconnect the IntelliBrite Spa LED light assembly cable from the junction box and discard the light assembly.



8. **INSTALLING THE INTELLIBRITE LED LIGHT WITH NEW GASKET:** Install a new gasket (P/N 79101600) during reassembly of the IntelliBrite LED light. A NEW LENS GASKET MUST BE USED EACH TIME THE LIGHT IS REASSEMBLED.
9. **Install the new gasket onto the lens:**
- With the light housing resting on its base, place the lens then the gasket on top of the light housing.
  - Place the face ring on top of the gasket. Make sure that the lens and gasket are centered correctly on the light housing.
  - Aligning the face ring and lens:** Align the face ring and lens so that the letter "O" in the word "TOP" and the small arrow above it) on the surface of the lens points to the pilot screw hole on the face ring.
  - Aligning the lens position with the LEDs:** While looking through the front of the lens, slightly rotate the lens until the vertical lines on the lens are in focus with the four (5) rows of LEDs below.

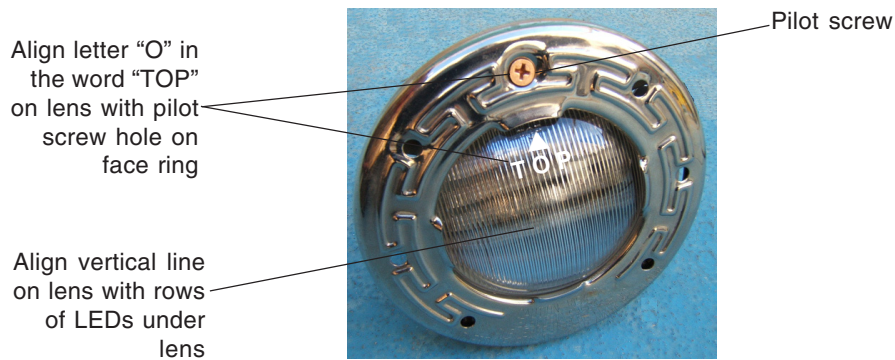

10. With the hook ends of the circular uni-tension wire clamp pointing down, spread the clamp and place it in the "U" recesses of the locking levers. Be sure the hook ends of the wire clamp are located between the pair of locking levers as shown below and that the clamp is properly engaged with all of the lock levers.
11. Place a cloth on the ground to protect the lens. Turn the light over so the lens is resting on the cloth. Tighten the bolt and nut until the distance between the ends of the clamp equals  $\frac{1}{4}$ -in or less.

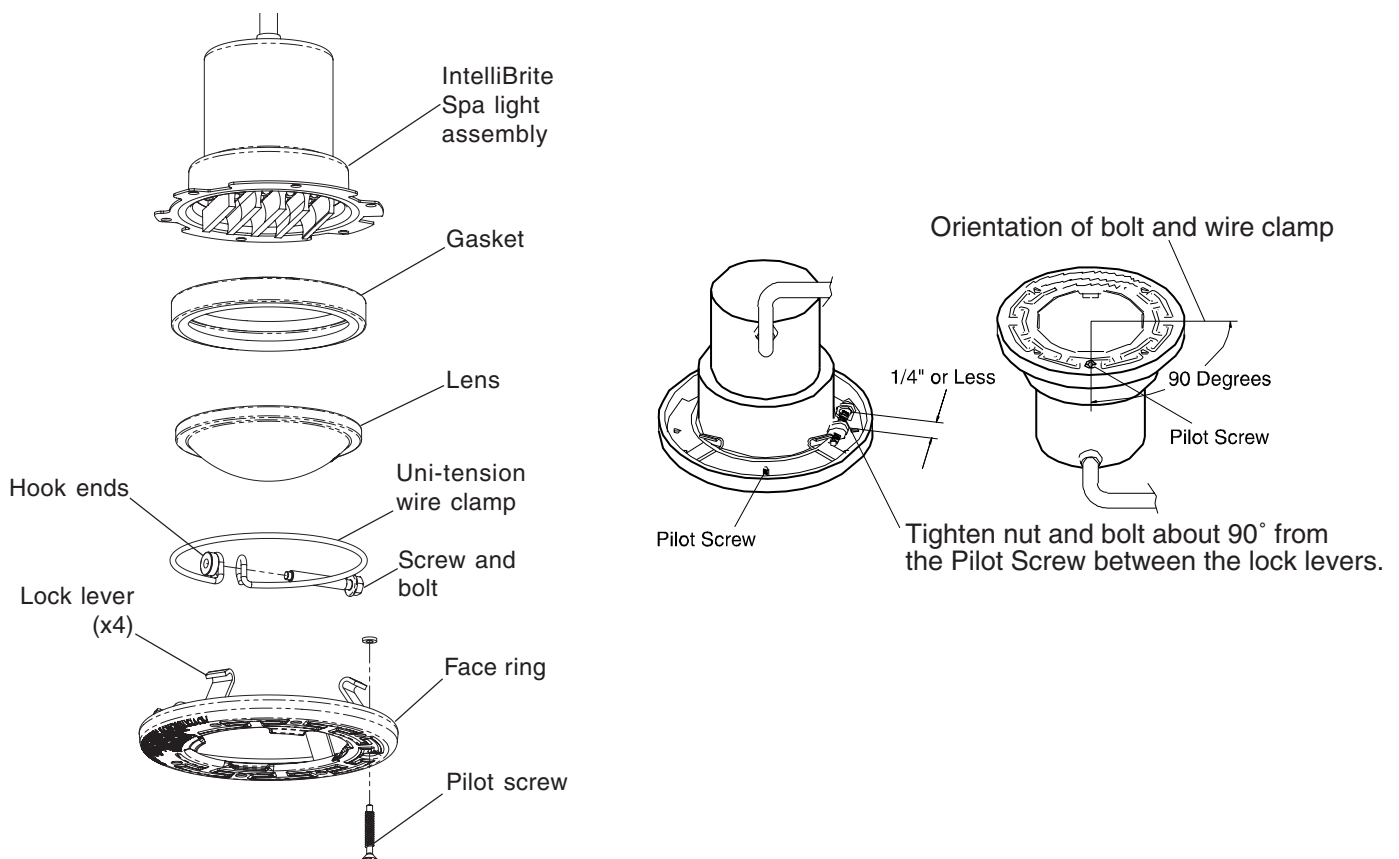



12. **Install the IntelliBrite light assembly into the niche:** Feed cord through conduit to Junction Box, leaving at least four (4) feet of cord at the light fixture to coil around the light; see Figure 1 (page 3). The four (4) feet of cord around the light allows the light to be serviced after the spa is filled with water.
13. Cut the cord at the Junction Box, leaving at least six (6) inches of cord to make connections.
14. Strip six (6) inches of the outer cord jacket to expose the three insulated wires (be careful not to damage the insulation on the three inner wires).
15. Connect all three (3) wires to the corresponding circuit wires in the Junction Box and secure the Junction Box cover in place.



**WARNING** - Never operate the underwater light for more than 10 seconds unless it is totally submerged in water. Without total submersion, the light assembly will get extremely hot and may result in serious burns or in breakage of the lens. This may result in serious injury to pool users, installers, or bystanders, or in damage to property.

16. Install the IntelliBrite light assembly into the niche. Tighten the special bronze pilot screw to secure in place.



**WARNING** - Use only the special pilot screw provided with this underwater light. This screw mounts and electrically grounds the housing securely to the mounting ring and wet niche. Failure to use the screw provided could create an electrical hazard which could result in death or serious injury to pool users, installers or others due to electrical shock.

17. Fill the spa until the light is completely submerged in the water. Before powering on the light, be sure the light is completely submerged in the water. The light should **never** be powered on out of the water for more than 10 seconds.
18. **Final check for proper light operation:** Switch on the main switch or circuit breaker, as well as the switch which operates the light. The light should illuminate when power is applied. If not recheck the installation steps starting with Step 12.

## IntelliBrite Spa Light Replacement Kit Part Numbers

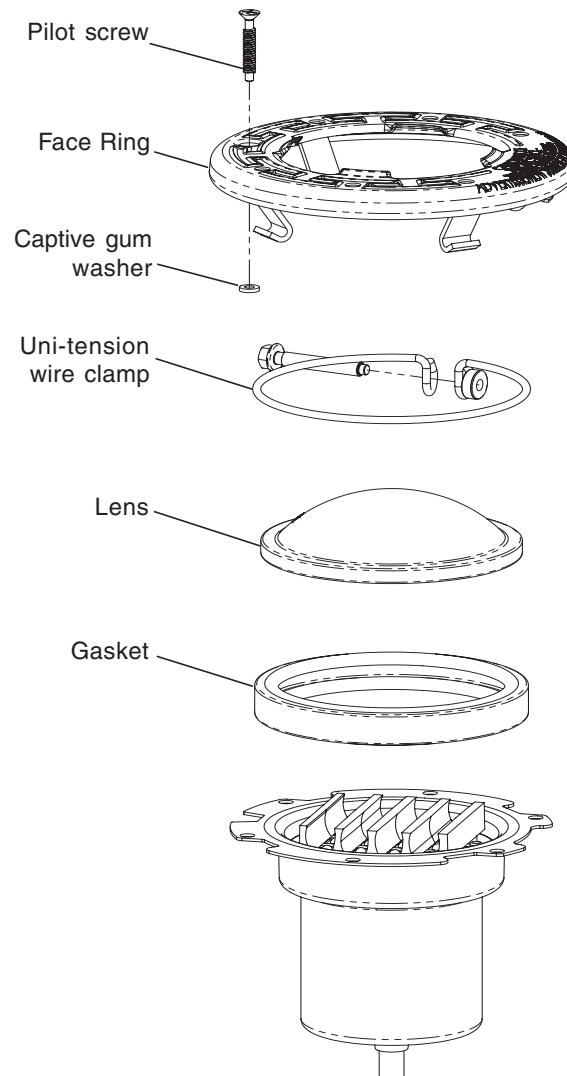

<b>Kit Part No.</b>	<b>Description</b>
640045	- Face Ring assembly, stainless steel. - Uni-tension wire clamp assembly. - Gasket, 4 in diameter, off white.
640046	- Gasket, 4 in diameter, off white. - Lens, IntelliBrite, Spa, 4 in diameter, tempered.
79104800	- Pilot screw, with captive gum washer.
79108500	- Gasket, 4 in diameter, off white.

**Note:** The 120 Volt IntelliBrite Spa light has an integrated 12 Volt transformer.





