

STA-RITE®

HIGH RATE SAND FILTERS

O W N E R ' S M A N U A L

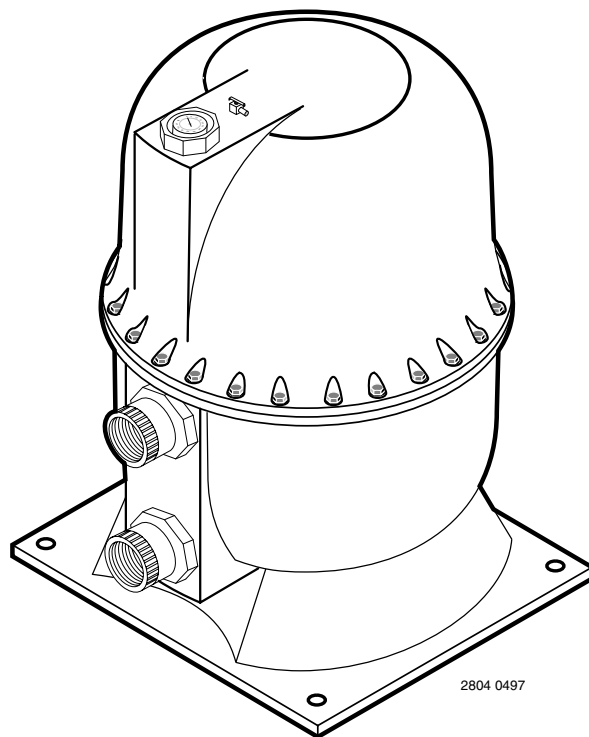

INSTALLATION, OPERATION & PARTS

MODELS

HRPB20

HRPB24

HRPB30



This manual should be furnished to the end user of this filter; its use will reduce service calls and chance of injury and will lengthen filter life.

Sta-Rite Pool/Spa Group

293 Wright Street, Delavan, WI 53115

International: 262-728-5551, FAX: 262-728-7550

www.starite.com

Union City, TN • Delavan, WI • Mississauga, Ont. • Murrieta, CA

© 2003, Sta-Rite Industries, Inc.

Printed in U.S.A.

S268 (Rev. 7/30/03)

HIGH RATE SAND FILTERS

To avoid unneeded service calls, prevent possible injuries, and get the most out of your filter, READ THIS MANUAL CAREFULLY!

The Sta-Rite 'HRPB' Series High Rate Sand Filter:

- Is designed to filter water for swimming pools.
- Is an excellent performer; durable, reliable.

Table of Contents

Safety Instructions.....	2-3
General Information/Specifications	4
Installation	5
Initial Filling.....	6
Filter Disassembly/Assembly.....	6-7
Startup/Operation	7
Backwash	8
Maintenance.....	8-9
Replace Internal Assembly	9
Winterizing.....	9
Repair Parts List	10-11
Troubleshooting Guide.....	12
Warranty.....	15

READ AND FOLLOW SAFETY INSTRUCTIONS!



 **DANGER**

 **WARNING**

 **CAUTION**

This is the safety-alert symbol. When you see this symbol on your valve or in this manual, look for one of the following signal words and be alert to the potential for personal injury.

DANGER warns about hazards that **will** cause serious personal injury, death or major property damage if ignored.

WARNING warns about hazards that **can** cause serious personal injury, death or major property damage if ignored.

CAUTION warns about hazards that **will** or **can** cause minor personal injury or property damage if ignored.

The label **NOTICE** indicates special instructions which are important but not related to hazards.

Carefully read and follow all safety instructions in this manual and on filter.

Keep safety labels in good condition.
Replace missing or damaged safety labels.



Incorrectly installed or tested equipment may fail, causing severe injury or property damage. Read and follow instructions in owner's manual when installing and operating equipment. Have a trained pool professional perform all pressure tests.

1. Do not connect system to a high pressure or city water system.
2. Use equipment only in a pool or spa installation.
3. Trapped air in system can cause explosion. BE SURE all air is out of system before operating or testing equipment.

Before pressure testing, make the following safety checks:

- Check all clamps, bolts, lids, and system accessories before testing.
- Release all air in system before testing.
- Tighten Sta-Rite trap lids to 30 ft. lbs. (4.1 kg-cm) torque for testing.
- Water pressure for test must be less than 25 PSI (172 kPa).
- Water temperature for test must be less than 100° F. (38° C).
- Limit test to 24 hours. After test, visually check system to be sure it is ready for operation. Remove trap lid and retighten hand tight only.

NOTICE: These parameters apply to Sta-Rite equipment only. For non Sta-Rite equipment, consult manufacturer.

	⚠ WARNING	BEFORE WORKING ON PUMP OR MOTOR
	Filter pumps require hazardous voltage which can shock, burn, or cause death	Disconnect power to motor.

⚠ WARNING

Hazardous pressure. Can cause severe injury or major property damage from tank blow up.

Release all pressure and read instructions before working on filter.

GENERAL INFORMATION

- Clean a new pool as well as possible before filling pool and operating filter. Excess dirt and large particles of foreign matter in the system can cause serious damage to the filter and pump.

⚠ Do not operate filter at water temperatures above 125°F (69°C).

⚠ NEVER operate this filter system at more than 50 pounds per square inch (50 PSI/345kPa) pressure!

TABLE I - SPACE REQUIREMENTS (Dimensions in inches/mm)

Model	A	B	C	D	E
HRPB20	7-1/2(191)	24(610)	24	20(508)	2" NPT
HRPB24	7-9/16(192)	28-1/2(724)	24	24(610)	2" NPT
HRPB30	7-7/8(200)	35(890)	32	30(762)	2" NPT

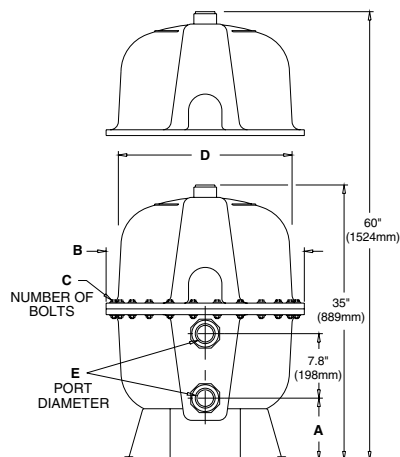

Figure 1 - Dimensions

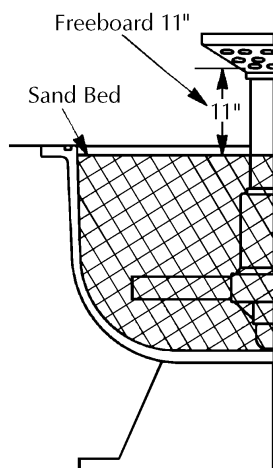

Figure 2 - Freeboard measurement

TABLE II - FILTER SPECIFICATIONS AND OPERATING INFORMATION

FILTER MODEL:	HRPB20	HRPB24	HRPB30
Filter Area	2.2 Ft. ² (.204M ²)	3.1 Ft. ² (.288M ²)	4.9 Ft. ² (.455M ²)
Flow Rate Range	33-44 GPM(125-167 L/m)	47-62 GPM(178-235 L/m)	73-98 GPM(276-371 L/m)
Max. Operating Pressure	50 PSI(345 kPa)	50 PSI(345 kPa)	50 PSI(345 kPa)
Max. Pressure Loss	2.8 PSI(19 kPa)	3.5 PSI(24 kPa)	6.8 PSI(47 kPa)
Freeboard (See Fig. 2)*	11" (28 cm)	11" (28 cm)	11" (28 cm)
Turnover in Hours:			
6 Hours	16,000 Gal.(60 560 L)	22,000 Gal.(83 270 L)	35,000 Gal.(132 475 L)
8 Hours	21,000 Gal.(79 485 L)	30,000 Gal.(113 550 L)	47,000 Gal.(177 895 L)
10 Hours	26,500 Gal.(100 303 L)	37,000 Gal.(140 045 L)	59,000 Gal.(223 315 L)
Qty. of Media Required:			
Cu. Ft.	2(56 640cm ³)	2-1/2(70 800cm ³)	4(113 280cm ³)
Weight (Pounds)	200(91 kg)	250(113 kg)	400(181 kg)

* Freeboard is the open space between the top of the sand bed and the tank backwash outlet.

NOTICE: 1 cubic foot (28 320 cm³) of sand weighs approximately 100 lbs. (45,4kg). DO NOT use a finer grade of sand than recommended.

RECOMMENDED SAND GRADES:

Use only: #20 Silica Sand, Size Range .40-.55mm., Uniformity Coefficient less than 1.75.

NOTICE: Use of other sands will reduce filter performance, may damage pump, and will void warranty.

Recommended:

1. Wedron Silica/Best Sand Co., Sand Grade: Wedron .45-.55mm., Effective Size .46mm, Uniformity Coefficient 1.22.
2. U.S. Silica - Silurian Filter Sand, Sand Grade: .45-.55 mm., Effective Size .48mm, Uniformity Coefficient 1.18.

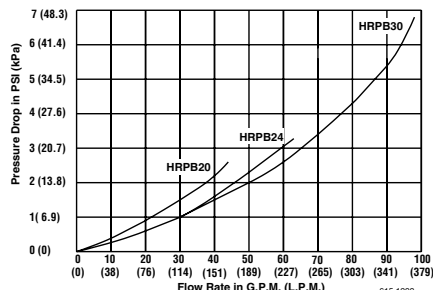

INSTALLATION

Installation of filter should only be done by qualified, licensed personnel. For assembly and filling instructions, see pages 6 and 7.

Filter mount must:

- Provide weather and freezing protection.
- Provide space and lighting for easy access for routine maintenance. (See Figure I and Table 1, Page 4, for space requirements.)
- Be on a reasonably level surface and provide adequate drainage.
- Be as close to pool as possible to reduce line loss from pipe friction.

Piping:

- Piping must conform to local/state plumbing and sanitary codes.
- Use pipe joint sealing compound or Teflon tape on all male connections of metal pipe and fittings (except unions). Use Teflon tape or Plasto-Joint Stik¹ on all male connections of plastic pipe and fittings. **DO NOT use pipe dope on plastic pipe; it will cause stress cracking of the pipe. Do not use sealant or tape on unions — assemble them dry and hand tight.**
- Do not damage union sealing surfaces and “O” Rings.
- Support pipe independently to prevent strains on filter or valve.
- Use 1-1/2” or 2” pipe to reduce pressure losses as much as possible.

NOTICE: Filter may be located away from pool, but for adequate flow larger pipe may be needed. For more information about hydraulic design, call Sta-Rite Customer Service.

- Fittings restrict flow; for best efficiency use fewest possible fittings.
- Keep piping tight and free of leaks: pump suction line leaks may cause trapped air in filter tank or loss of prime at pump; pump discharge line leaks may show up as dampness or jets of water.
- **NOTICE:** Overtightening can crack filter ports.

Valves:

- A check valve installed ahead of filter inlet will prevent contaminants from draining back into pool.
- A check valve installed between filter and heater will prevent hot water from backing up into filter and deforming internal components.
- Install Sta-Rite Two Position Slide Valve or Multiport Selector Valve with filter. See Table III.
- Filter ports and valve ports are furnished with union connections.
DO NOT use pipe sealants on union collar (nut).
- Use care before assembly not to damage union sealing surfaces or O Ring.

Wastewater:

- Be sure all provisions for waste water disposal meet applicable local, state or national codes. 100 gallons (379 liters) or more of pool water will be discharged during filter backwashing. Do not discharge where water will cause flooding or damage.

Assembly:

See Pages 6 and 7 for assembly and filling instructions.

TABLE III - Sta-Rite valves for use with filters

Port Size	Part Number
2" 1-1/2"	Multi-port WC212-144P
	WC212-143P
1-1/2" 2"	Brass Slide WC212-135D
	WC212-136D
2" 2"	Plastic Slide WC212-134P

NOTICE: Use of valves other than those listed above could cause reversed water flow through filters and damage to internal filter components.

¹ Lake Chemical Co., Chicago, IL

⚠ CAUTION

⚠ WARNING



**Hazardous pressure.
Can cause severe injury or major property damage from tank blow up.**

Release all pressure and read instructions before working on filter.

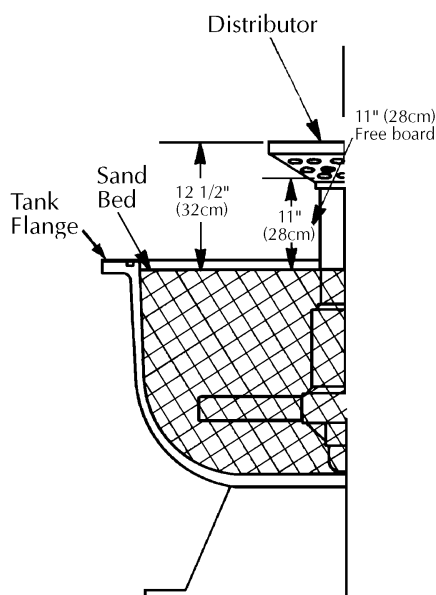

Figure 3 - Fill sand bed as shown.

FILTER DISASSEMBLY/ASSEMBLY

⚠ To avoid equipment damage and personal injury, never change handle position on control valve while pump is running.

BEFORE DISASSEMBLING FILTER:

- ⚠**
1. STOP PUMP.
 2. OPEN air release valve and drain fitting.
 3. WAIT until all pressure is released and water drained from filter tank and system before loosening clamp knobs.

Disassembly:

1. Backwash filter according to instructions under "Filter Backwash Procedure", Page 7 (when first filling a new filter, omit this step).
2. Stop pump.
3. Open air release valve (Key No. 7, Page 10) on top of filter tank to release all air pressure from inside of tank and system.
4. Remove filter drain plug (Key No. 19) and drain all water from tank.
5. To equalize flange stresses, loosen bolts alternately (that is, on opposite sides of tank) around tank. Remove bolts.
6. Being careful not to damage Cord Ring (Key No. 24), lift upper tank shell (Key No. 9) off lower tank shell (Key No. 14).

Filling Filter with Sand:

1. See Page 4 for correct sand grade and quantity.
2. Before pouring sand into filter, look inside and check internal assembly (Key No. 12) for broken or loose laterals (Key No. 12d and 12e) caused by shipping damage. Replace if necessary.
3. To eliminate stress on laterals fill tank half-full of water before loading sand.
4. When full, top of sand bed should be about 12-1/2" (31.75 cm) below top of distributor (about 1-1/2" (3.8 cm) below tank flange (see Figure 3).
5. Wash all sand and dirt away from cord ring sealing area.
6. Assemble filter according to instructions, pages 6 and 7.

Assembly:

1. Remove cord ring (Key No. 24, Page 10) slowly to avoid stretching or tearing it.
2. Inspect cord ring for cuts, nicks, etc. If cord ring is damaged, deformed, or has lost its resiliency, replace with a new one.
3. Clean cord ring area of tank shell (both halves) and cord ring.
4. Carefully install cord ring and upper tank shell (Key No. 9).

NOTICE: Do not lubricate cord ring. Lubricants attract dirt and grit and may (especially when petroleum based) damage cord ring and void warranty.

NOTICE: Be sure upper tank shell contacts cord ring surface evenly and seal area is clean and free from dirt.

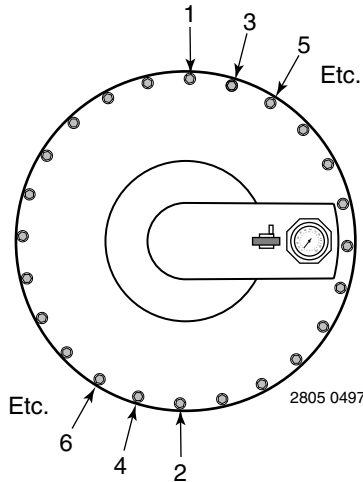

Figure 4 - Tighten bolts in sequence shown.

5. Install bolts, washers and nuts. Tighten nuts evenly and alternately (that is, on opposite sides of tank) around filter. See Figure 4.

NOTICE: BE SURE to tighten alternate bolts on opposite sides of tank - DO NOT tighten one bolt, then the next, etc.

NOTICE: Torque bolts to 20 ft.-lbs. torque for 20"(508mm) tanks and to 30 ft.-lbs. for 24"(610mm) and 30"(762mm) tanks. Do not over-torque.

6. Install Fill Cap and Air Release/Drain Plug package and O-Rings (see exploded view, Page 10).

Startup (Multi-port Valve):

1. With pump OFF, set valve to 'BACKWASH' position.
2. Open air release valve (Key No. 7, Page 10).
3. Start pump, circulating water backwards through filter to waste.
4. Close air release valve when a steady stream of water is expelled.
5. Run pump five minutes or until waste water is clear (this purges excess fine particles from system).
6. Stop pump; set valve handle to 'RINSE' position.
7. Start pump; run pump for one minute.
8. Stop pump; set valve to 'FILTER' position. Follow instructions under 'Regular Operation' (below) to place filter in service.

Startup (Slide Valve):

1. With pump OFF, raise handle to fully extended position.
2. Open air release valve (Key No. 7, Page 10).
3. Start pump, circulating water backwards through filter to waste.
4. Close air release valve when a steady stream of water is expelled.
5. Run pump five minutes or until waste water is clear (this purges excess fine particles from system).
6. Stop pump; lower handle completely to 'FILTER' position and pin in place. Follow instructions under 'Regular Operation' (below) to place filter in service.

REGULAR OPERATION

▲ WARNING Do not operate this filter at more than 50 PSI (345kPa) under any circumstances!

Run Filter:

1. With pump OFF, set valve to 'FILTER' position.
2. Fill trap on pump with water.
3. Open air release valve on top of filter assembly (Key No. 7, Page 10); start pump.
4. When steady stream of water comes from air release valve, close the valve.
5. With filter operating, record pressure gauge reading in owner's manual. When reading is 10 PSI (70kPa) above initial reading, backwash filter.

CAUTION

Backwash Filter (Multi-Port Valve):

 **To prevent equipment damage and possible injury, turn pump OFF before changing valve position.**

1. With pump OFF, set valve to 'BACKWASH' position.
2. Open air release valve (Key No. 7, Page 10).
3. Start pump, circulating water backwards through filter to waste.
4. Close air release valve when a steady stream of water is expelled.
5. Backwash until water runs clear.
6. Stop pump; set valve to 'RINSE' position.
7. Start pump; run pump for one minute.
8. Stop pump; set valve to 'FILTER' position.
9. Filter is now ready for service.
10. Open air release valve and release ALL pressure from system.
11. Follow 'Run filter' procedure to restart system.

Backwash Filter (Slide Valve):

 **To prevent equipment damage and possible injury, turn pump OFF before changing valve position.**

1. With pump OFF, raise valve handle to fully extended position.
2. Open air release valve (Key No. 7, Page 10).
3. Start pump, circulating water backwards through filter to waste.
4. Close air release valve when a steady stream of water is expelled.
5. Backwash until water runs clear.
6. Stop pump; lower handle completely to 'FILTER' position and pin in place.
7. Filter is now ready for service.
8. Open air release valve and release ALL pressure from tank and system.
9. Follow 'Run filter' procedure (above) to restart system.

MAINTENANCE

General:

- Wash outside of filter with a mild detergent and water. Rinse off with hose.
NOTICE: DO NOT use solvents to clean filter; solvents may damage plastic components in system.
- Inspect sand bed at least once a year to remove foreign material which has not been backwashed out of system.

 **WARNING** Follow instructions on Pages 6 and 7 when disassembling and assembling filter.

NOTICE: When the sand bed gets hard and crusty on top, remove all the old sand and replace it with new sand.

NOTICE: Open air bleed valve and bleed all air from filter each time pump is stopped and restarted.

Weekly Pool Equipment Inspection:

1. Check pressure during operation. When pressure is 10 PSI (70kPa) higher than initial operating pressure, backwash filter (see instructions, Page 7).

Install four short laterals
opposite inlet/outlet pipes.
(Model HRPB20 only.)

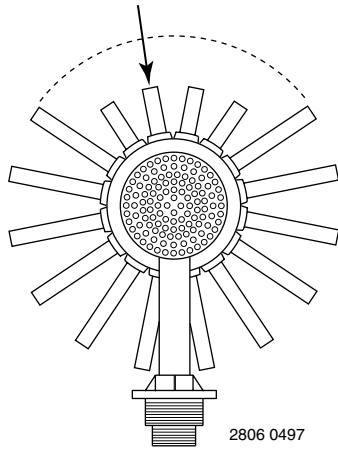

Figure 5 - Long laterals opposite inlet/outlet will interfere with assembly.

2. Skimmer basket - remove debris.
3. Stop pump, release all pressure from system. Remove trap cover and basket, remove debris.
4. Bleed air from filter each time system is started.
5. Check pump for leaks. If found, see pump owner's manual.
6. Check pump strainer lid for tightness. Do not overtighten!

Replace Internal Assembly:

1. Disassemble filter according to instructions in "Filter Disassembly" Page 6.

▲ WARNING To avoid severe injury and major property damage, follow instructions on Pages 6 and 7 when disassembling and assembling filter.

2. Remove sand from filter.
3. Remove union adapters and fitting nuts from ports; remove internal assembly.
4. Glue inlet and outlet piping into hub of new center column. Use only PVC to ABS cement.

▲ WARNING To avoid serious personal injury or property damage, follow cement manufacturer's instructions exactly.

5. Twist-lock new laterals into place until you feel a distinctive click. The slots must be face down. **Gluing is not required...**nor recommended.

NOTE: If you elect to glue the laterals, use only ABS to ABS cement.

6. Move air relief filter assembly to new internal assembly.
7. Be sure Quad rings are clean and seated in flange grooves in inlet/outlet pipes. Reinstall internal assembly in lower shell. Assemble locknuts dry and tighten to 10 ft/lbs. (1.38 kg.m) torque.
8. Connect inlet/outlet pipes to piping system. Assemble union adapters with silicone RTV sealant and tighten until thread bottoms out against stop on inlet/outlet ports.
9. To refill, reassemble, and restart filter, turn to "Filter Disassembly/Assembly", Pages 6 and 7.

▲ WARNING To avoid severe injury or major property damage, exactly follow "Assembly" instructions, Pages 6 and 7.

WINTERIZING

1. Open air release valve; open all system valves. Position multiport valve between port positions to allow air passage to all ports.
2. Remove drain plugs from trap, pump, valve and filter.
3. Drain system piping.
4. Cover with plastic or tarpaulin to protect from weather.
5. Protect from freezing.

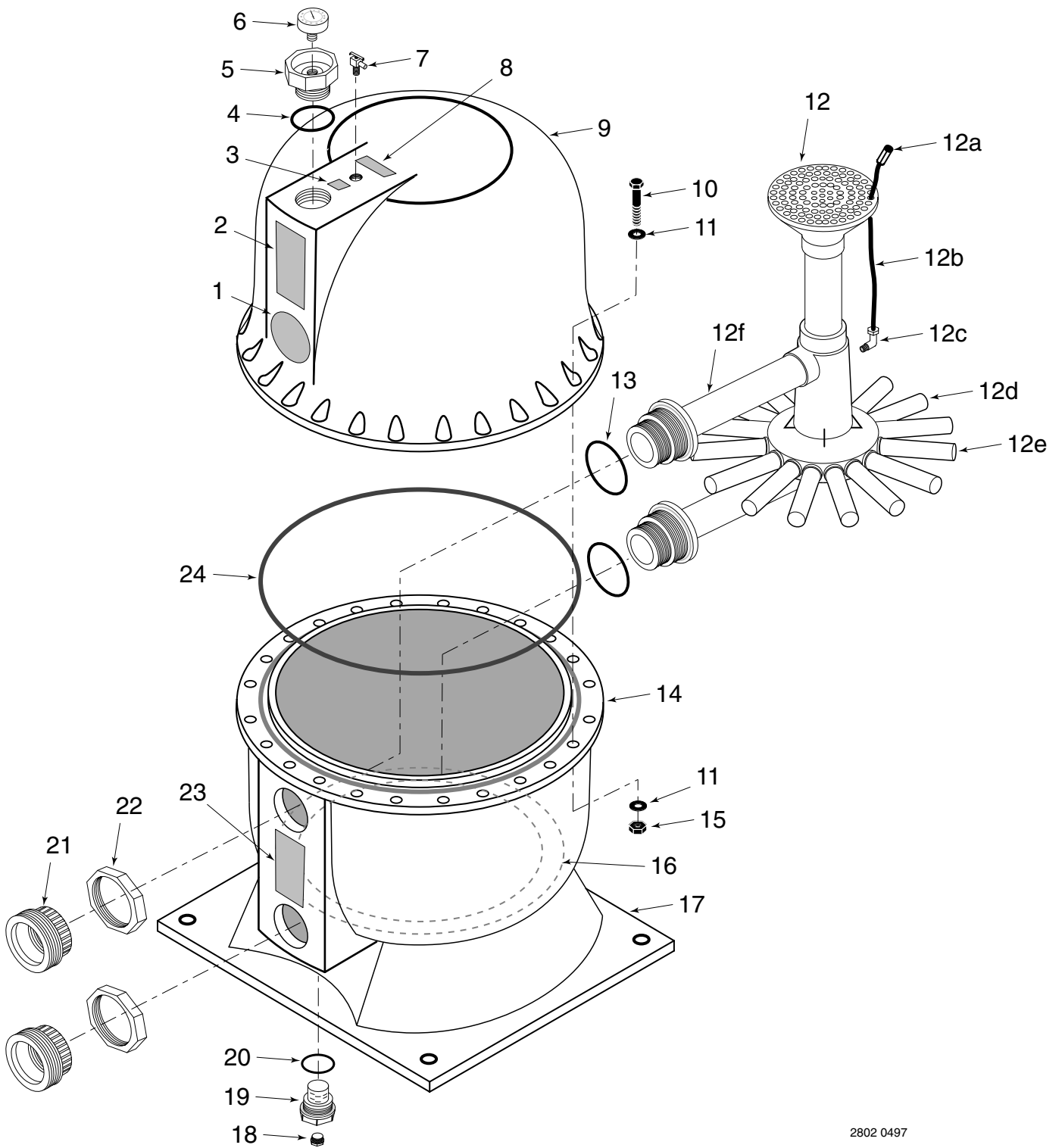

2802 0497

REPAIR PARTS LIST

Key No.	Description	Qty.	HRPB20	HRPB24	HRPB30
1	Sta-Rite Logo	1	32145-4001	32145-4001	32145-4001
2	Model Label	1	32155-4028	32155-4029	32155-4030
3	NSF Seal	1	Not Available	Not Available	Not Available
4	O-Ring*	1	35505-1317	35505-1317	35505-1317
5	Fill Cap Assembly	1	24750-0065	24750-0065	24750-0065
6	Pressure Gauge*	1	33600-0023T	33600-0023T	33600-0023T
7	Air Release Valve*	1	U212-252D	U212-252D	U212-252D
8	Decal: "WARNING: Turn Off Pump..."	1	WC27-23	WC27-23	WC27-23
9	Upper Shell	1	WC31-253P	WC31-251P	WC31-255P
10	Bolt, 3/8-16x2 1/4"	24	U30-884ZP	-	-
10	Bolt, 1/2-13x2 1/2"	24	-	U30-91C	-
10	Bolt, 1/2-13x2 3/4"	32	-	-	U30-901ZP
11	Washer, Flat 3/8"	48	U43-62ZP	-	-
11	Washer, Flat 1/2"	48	-	U43-129ZP	-
11	Washer, Flat 1/2"	64	-	-	U43-129ZP
12	Internal Assembly (Kit)	1	WC237-514P	24751-0110	24752-0110
12A	Air Bleed Filter	1	WC8-126	WC8-126	WC8-126
12B	Tube	1	WC37-384P	WC37-384P	WC37-384P
12C	Compression Elbow	1	WC78-84P	WC78-84P	WC78-84P
12D	Lateral - Short	4	24735-0011	-	-
12E	Lateral - Long	12	24600-0003	-	-
12E	Lateral - Long	16	-	24700-0075	24700-0075
12F	Tank Fitting Assembly	2	WC178-93P	24751-0010	24751-0010
13	Quad Ring	2	35515-1296	35515-1296	35515-1296
14	Lower Shell†	1	WC31-252P	WC31-250P	WC31-254P
15	Nut, 3/8-16	24	U36-38C	-	-
15	Nut, 1/2-13	24	-	U36-39C	-
15	Nut, 1/2-13	32	-	-	U36-39C
16	Tape	2	37685-0006A	37685-0006A	37685-0006A
17	Base	1	23900-0105	23901-0005	23901-0005
18	Plug, 1/4"	1	WC78-40T	WC78-40T	WC78-40T
19	Drain Plug Sub-Assembly	1	24700-0411	24700-0411	24700-0411
20	O-Ring	1	U9-269	U9-269	U9-269
21	Union Adapter	2	U11-198P	U11-198P	U11-198P
22	Fitting Nut, 2"	2	24752-0049	24752-0049	24752-0049
23	Inlet - Outlet Label	1	32155-4004	32155-4004	32155-4004
24	Cord Ring	1	24750-0006	24751-0006	24752-0006
•	Lateral Extension Adapter**	***	24700-0029	24700-0029	24700-0029

• Not illustrated.

* Included in Air Release/Fill Cap Package, Part No. 24750-0027.

** Available for lateral repairs.

*** Quantity as required.

† When ordering Lower Shell, also order Key Nos. 16 (tape) and 23 (Inlet-Outlet Label).

TROUBLESHOOTING GUIDE

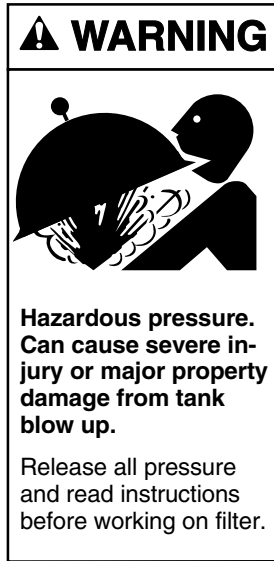

1. Short Cycle between backwashes:

NOTICE: Time between backwashes will vary with each installation and between different areas of the country. Ask installer about normal backwash interval in your area. The following causes and remedies are for cycle times shorter than normal for your area.

- A. Flow rate too high or filter too small; consult dealer for system sizing recommendations.
- B. Water is chemically out of balance; consult pool serviceman.

2. Low Flow/High Pressure:

- A. Pipe blocked downstream from filter; remove obstruction.
- B. Piping too small; use larger pipe (consult dealer for sizing).
- C. Filter area too small or pump too large; consult dealer for recommendation.

3. Low Flow/Low Pressure:

- A. Pump too small; consult dealer for recommendations.
- B. Plugged pump, plugged line, or plugged hair and lint trap; clean thoroughly.

4. Pool Water Not Clear:

- A. Water is chemically out of balance; consult pool professional.
- B. Inadequate turnover rate; consult dealer about equipment sizing.
- C. Sand in pool means broken lateral.

⚠ WARNING To avoid severe injury or major property damage, follow instructions under 'Disassembly' and 'Assembly' (pages 6 and 7)!

1. Follow filter disassembly procedure, Page 6.
2. Replace lateral according to instructions supplied with new lateral (See Page 9).
3. Reassemble filter according to instructions, Pages 6 and 7.

STA-RITE LIMITED WARRANTY

Pumps, filters, skimmers, underwater lights (except bulbs), accessories and fittings manufactured by Sta-Rite are warranted to be free of defects in material and workmanship for one (1) year from date of installation.

Product specific warranties: **Year from date of installation**

<i>HRPB, DEPB, System 3, System 2 and Posi-Clear</i>	
Tanks	10 years
Internal filter components and valves	1 year
<i>Max-E-Therm - Pool/Spa Heaters</i>	
Heater Enclosure only (Upper RH & LH; lower enclosure; and control board enclosure)...	10 years
<i>Automatic Pool Cleaners including Hose</i>	2 years
<i>Cristal-Flo filters - Tanks</i>	
Valve and internal components.	1 year
<i>Posi-Flo II - Tanks</i>	
Elements	1 year
<i>PRC Cartridge -</i>	
Filter Tanks	5 years pro-rated (1st 2 years full)
Elements	1 year
<i>System 2 Above Ground Systems - Tanks</i>	
Pumps / Platform and Internals	1 year
<i>Pumps</i>	
When equipped with A.O. Smith 2-compartment motors (Does not include pumps sold as part of a systems package)	2 years
<i>Traps / In-Line Strainers</i>	1 year
<i>Vertical Commercial Filter - Tanks</i>	
Internals	1 year
<i>Horizontal Commercial Filter</i>	
Tanks	5 years
(Years 6-9, Prorated declining 20%/year, Yr. 10 - 10%)	
Internals	1 year

* Full warranty coverage is in effect for one year after installation. The pro-rated warranty covers the *tank only* during the 2nd through 10th year after installation. The amount covered decreases by 10% each year. (ie., 2nd year 90% covered, 3rd year 80% covered, etc.).

The foregoing warranties relate to the original consumer purchaser ("Purchaser") only. Sta-Rite shall have the option to repair or replace the defective product, at its sole discre-

tion. Purchasers must pay all labor and shipping charges necessary to replace the product covered by this warranty. Requests for warranty service must be made through the installing dealer. This warranty shall not apply to any product that has been subject to negligence, misapplication, improper installation or maintenance, or other circumstances which are not in Sta-Rite's direct control.

This warranty sets forth Sta-Rite's sole obligation and Purchaser's exclusive remedy for defective products.

STA-RITE SHALL NOT BE LIABLE FOR ANY CONSEQUENTIAL, INCIDENTAL OR CONTINGENT DAMAGES WHATSOEVER.

THE FOREGOING WARRANTIES ARE EXCLUSIVE AND IN LIEU OF ALL OTHER EXPRESS WARRANTIES. IMPLIED WARRANTIES, INCLUDING BUT NOT LIMITED TO THE IMPLIED WARRANTIES OF MERCHANTABILITY AND FITNESS FOR A PARTICULAR PURPOSE, SHALL NOT EXTEND BEYOND THE DURATION OF THE APPLICABLE EXPRESS WARRANTIES PROVIDED HEREIN.

Some states do not allow the exclusion or limitation of incidental or consequential damages or limitations on how long an implied warranty lasts, so the above limitations or exclusion may not apply to you. This warranty gives you specific legal rights and you may also have other rights which vary from state to state.

Supersedes all previous publications.

Sta-Rite Industries, Inc.,
293 Wright St., Delavan, WI 53115

▲ Retain Warranty Certificate (upper portion) in a safe and convenient location for your records.

DETACH HERE: Fill out bottom portion completely and mail within 10 days of purchase/installation to:

▼ Sta-Rite, Attn: Warranty Dept., 293 Wright St., Delavan, WI 53115

STA-RITE®



Warranty Registration Card

Name _____

Years pool has been in service less than 1 1-3 3-5 5-10 _____

Address _____

Purchased from:
 Company name _____

City _____ State _____ Zip _____

Address _____

Purchase Date _____

City _____ State _____ Zip _____

Product Purchased _____

New installation Replacement _____

Please send me more information on these other products from Sta-Rite.

Type of Pool Inground Vinyl Fiberglass Gunite _____

- Pumps Filters Automatic Pool Cleaners
- Maintenance Equipment Test Strips
- Heaters

Size of Pool _____

